

## Front Brake Drum Assembly

(243)

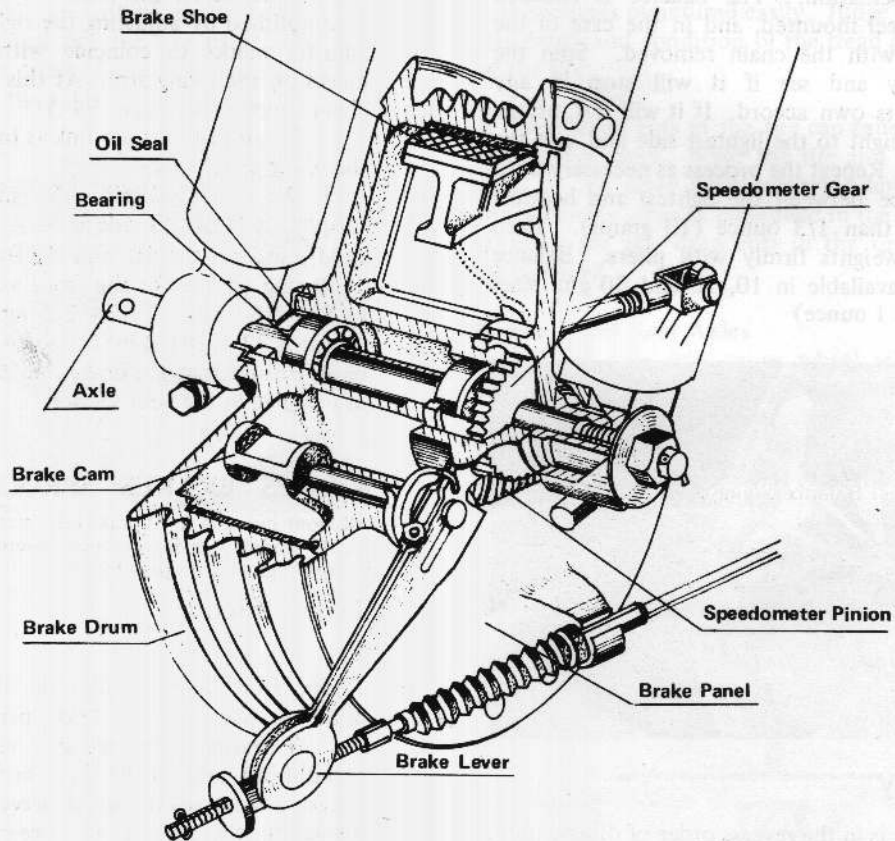

## b. Rear Hub

The rear hub consists of the brake drum; rear brake mechanism — brake panel, brake shoes; the sprocket which receives engine power and turns the rear wheel; and the coupling. The brake panel is mounted on the right side of the brake drum, and the coupling on the left side. The rear brake

drum, which is of the same construction as the front drum, fits against the coupling separated by rubber shock dampers that buffer torque changes.

A bearing and oil seal are pressed into the coupling, and the sprocket is bolted against it.

In the H1 a ventilator is provided in the rear brake panel.

## Rear Hub Mechanism

(244)

