

# SUDDO

M I K U N I

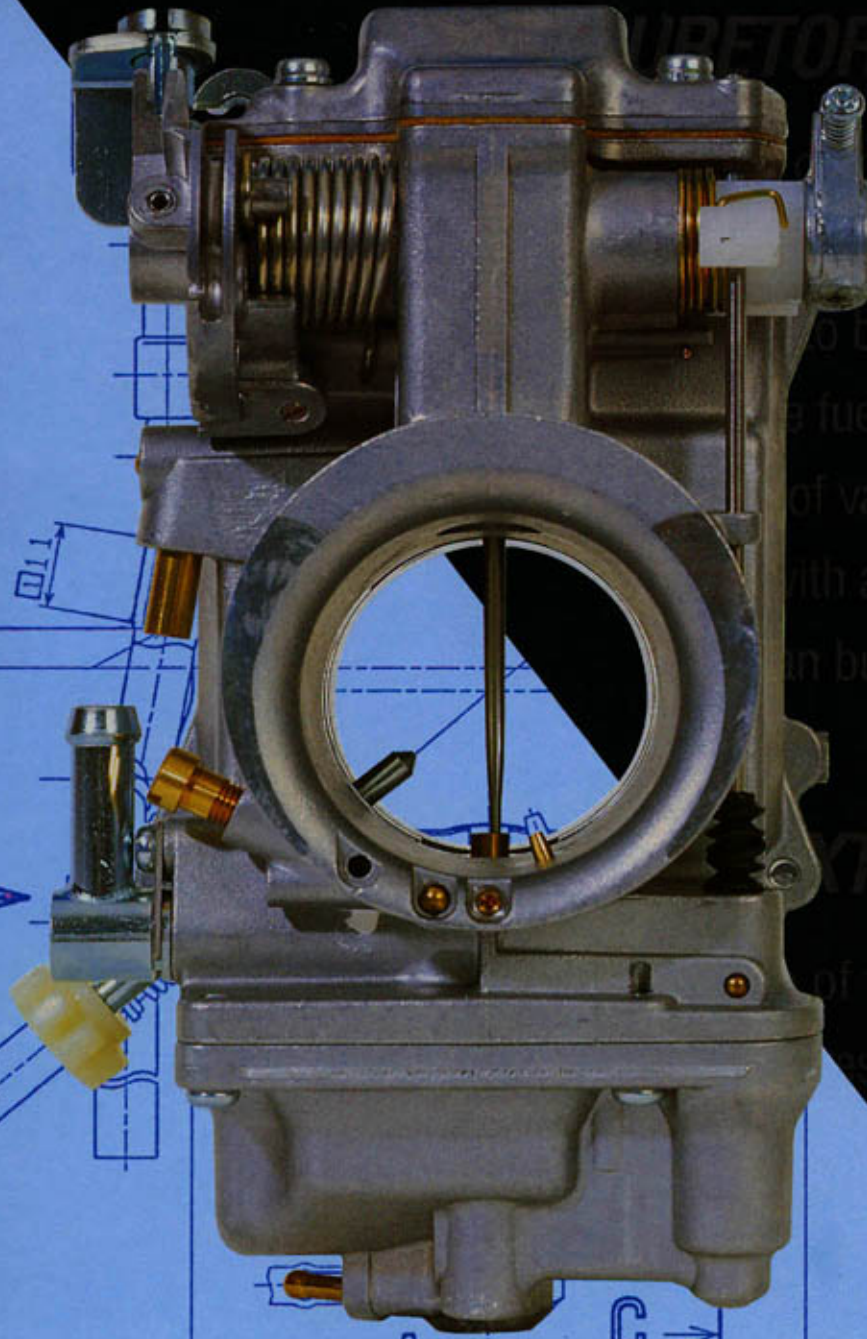

# MIKUNI

T U N I N G M A N U A L

NOTE

1. THE THROTTLE VALVE

# Venturi Operation

## Operation of a Simple Venturi

The Mikuni slide type carburetors described in this manual are also known as "variable venturi" type carburetors. A venturi is a restriction within the carburetor designed to speed up the air flowing through the carb. It is at the point of the smallest cross section that the incoming air flow will have the greatest velocity. As air flow speeds up to pass through the venturi, it loses pressure. It is at this point that the pressure within the carb throat will be at its lowest; this is called "depression". At this point of maximum depression, the fuel will be introduced to the air stream. In order to transfer fuel from the fuel chamber into the carburetor venturi, a small tube is placed into the venturi which connects the fuel load in the chamber to the venturi. The fuel chamber is open to atmospheric pressure (15 psi approx.) and the pick up tube is exposed to the depression within the venturi. The difference in pressure will attempt to equalize through the pick up tube, pushing fuel from the fuel chamber into the venturi. The fuel is mixed with the incoming air and delivered to the engine down stream. This is the basic principle by which all carburetors operate.

It is important to remember that it is the pressure difference between the fuel chamber and the venturi which pushes the fuel into the intake air stream. The presence of engine vacuum alone is not enough to draw fuel into the intake port. Without the atmospheric pressure in the fuel chamber, the fuel could not be delivered into the intake port.

The above model will serve a single speed engine very well with the venturi becoming the throttle. The engine will run at one speed only, depending upon the size of the venturi. Because motorcycles are operated at various engine speeds, there needs to be a way to control the speed of the engine.

In order to throttle down this wide open carburetor design, Mikuni has inserted a slide which crosses the carburetor throat to control air flow to the engine, limiting engine speed according to slide lift. This slide lift varies the cross section of the carburetor bore at the venturi point. This is how slide carburetors become known as "variable venturi". These variable venturi type carburetors are very good at maintaining high air speeds within the carburetor throat and generally offer better overall performance than most other carburetor designs.

From this simple fuel delivery circuit, carburetor designers will add and divide this circuitry in order to tailor the mixture available to the engine, enabling it to run accurately at a wide variety of speeds and loads.

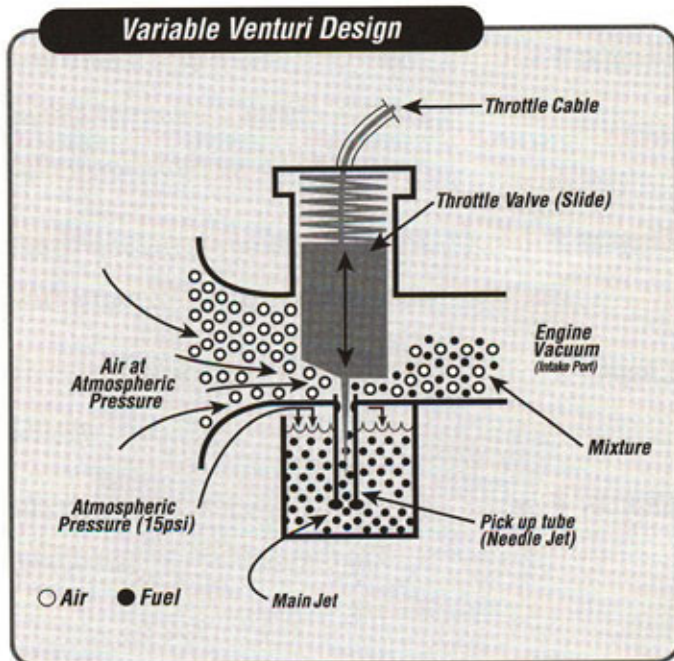

## Operation of a Variable Venturi

All Mikuni motorcycle carburetors described in this manual are of the variable venturi type. With this type of carburetor, the maximum depression zone is beneath the throttle valve (slide) which is raised and lowered by the throttle cable, controlling the speed of the engine. As shown in the drawing, the pick up tube (needle jet) is positioned to meter the fuel delivery of the tube from about a 1/4 throttle to 3/4 throttle. From 3/4 to full throttle, the needle will be too narrow to affect the fuel flow of the tube. From this point on, the fuel flow of the tube is metered by the main jet which is positioned at the bottom of the tube.

The above description is a simple model of the main circuit to most Mikuni slide type carburetors. The following chapter contains a more complete description of Mikuni motorcycle carburetor design and fuel delivery circuits.

## Simple Venturi Design

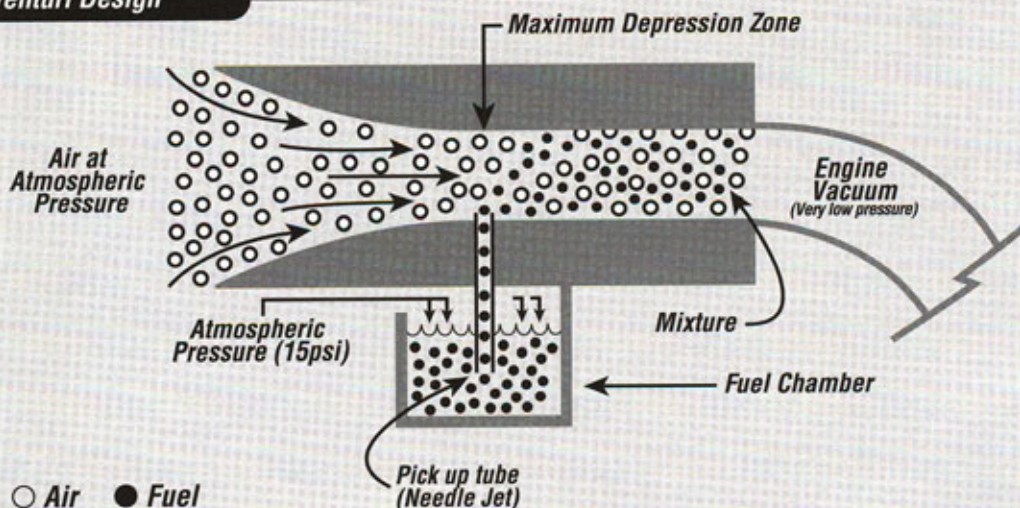

# General Mikuni Slide Carb Circuitry

This manual is intended as a guide for users of Mikuni carburetors who want to learn the basic methods of tuning and adjusting to obtain top performance and fuel economy. The arrows that appear in the drawings in this text show direction in which air, fuel, and air-fuel mixture flows.

**Information herewith obtained from Mikuni engineering data and manuals.**

## 1. CARBURETOR FUNCTION

The function of a carburetor is to deliver a combustible air-fuel mixture to the engine. However, in order to be effective, it must first break the fuel into tiny particles (in the form of vapor) and then mix the fuel with air in a proper ratio so it can burn without leaving excess fuel or air.

## 2. AIR-FUEL MIXTURE (Fig.1)

The mixture of the air-fuel ratio is generally expressed by its relative weight proportion. For example, the amount of air required for complete combustion of 1 gram of fuel under normal conditions is:

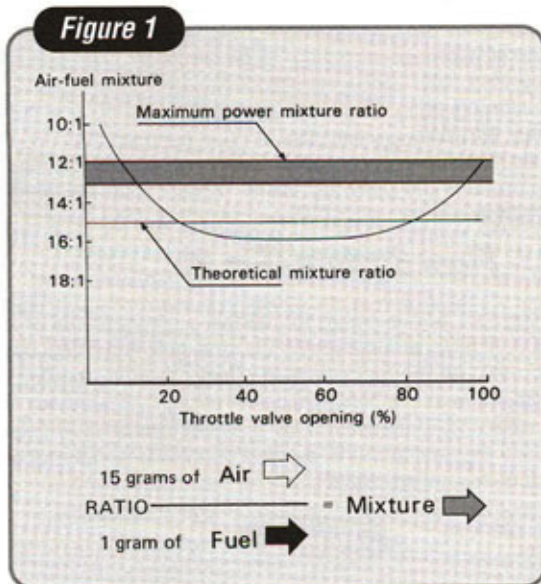

Varying mixture ratios are required for the engine depending on operating conditions. Although the required mixture ratio varies more or less with the type of engine, its cooling efficiency, etc., the mixture ratio shown in fig. 1 is required for ordinary engines. In the high speed range the ratio of about 12 to 13 grams of air for 1 gram of fuel produces the maximum output. However, in the case of an engine with low cooling efficiency, a somewhat richer mixture (10 to 12 grams of air against 1 gram of fuel) may be required to prevent seizure of the engine.

## 3. FUNCTIONS AND CONSTRUCTION MIKUNI SLIDE TYPE CARBURETORS

Motorcycle engines are operated under a wide range of conditions, from idling with the throttle valve (Fig.2(1)) remaining almost closed, to the full load (the maximum output) with the throttle valve fully opened. In order to meet the requirements for the proper mixture ratio under these varying conditions, a low-speed fuel system (the pilot system) and a main fuel system (the main system) are provided in Mikuni Slide-type carburetors, except Mikuni TMS.

## A. - The Pilot System

### Low-speed fuel system (Fig.2 and Fig.3)

Since the engine is operated with the throttle valve almost closed at idling or in the low speed range, the velocity of air flowing through the needle jet (2) is slow. Consequently, a vacuum strong enough to draw fuel from the needle jet in main fuel system is not created. The fuel supply during this low speed operation is controlled by means of the pilot outlet (3) and the bypass (4) that are situated nearest to the engine. At idle, when the throttle valve is slightly opened, fuel metered by the pilot jet (5) is mixed with air adjusted in a proper amount by the air screw (6) and is broken into fine vapor particles.

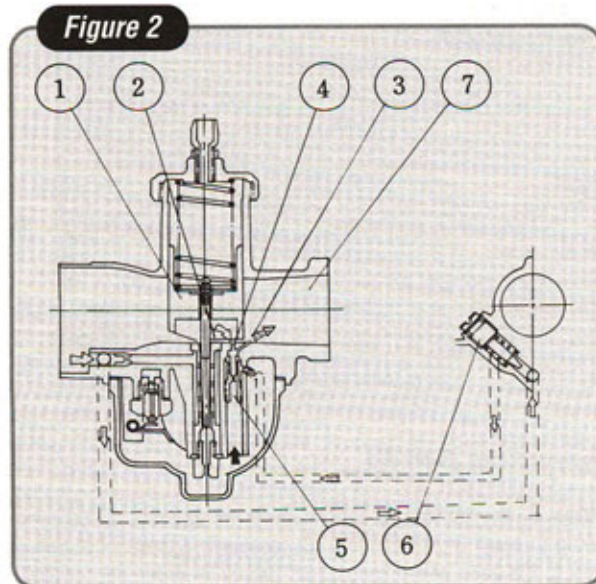

The mixture is again mixed with air coming from the bypass and is drawn into the pilot outlet to mix with air flowing through the main bore (7). The fuel mixed with air at this stage then goes into the engine. When the throttle valve is opened slightly during low speed operation, the pilot outlet alone cannot supply the required fuel and the shortage has to be made up

with fuel injected from the from the bypass. The adjustment of the mixture ratio during this stage is made by the pilot jet and the air screw, as in the case of a two-hole type fuel system (Fig.3). While at low speed operation, if full throttle is initiated a similar shortage of fuel again has to be injected from the bypass until enough (vacuum) can be created to draw fuel from the main fuel system. There is also a one-hole type low speed fuel system mainly used for carburetors having a small main bore. The process of producing the air fuel mixture and of adjusting the mixture ratio are the same as in a two-hole type low speed system.

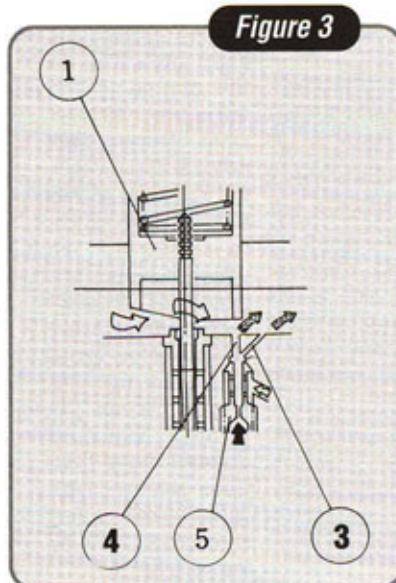

# General Mikuni Slide Carb Circuitry

## B. - Main Fuel System

On Mikuni VM-type carburetors, the pilot system and the main system are of independent construction. The fuel flow in these two systems is shown in Fig.5. There are two types of main fuel system; one is a primary type used widely for 2-cycle engines and the other is a bleed type which is normally used for 4-cycle engines as well as for rotary valve 2-cycle engines.

Sudco uses primary type needle jets in most 4-cycle VM applications. It is important to note (Fig.5) that the main system mixture delivery is in addition to the mixture delivered by the pilot system. Therefore, adjustments to the pilot system should be made first, as they will affect the adjustment of the main system to a diminishing extent as the throttle is opened from 1/4 to full throttle.

Figure 5

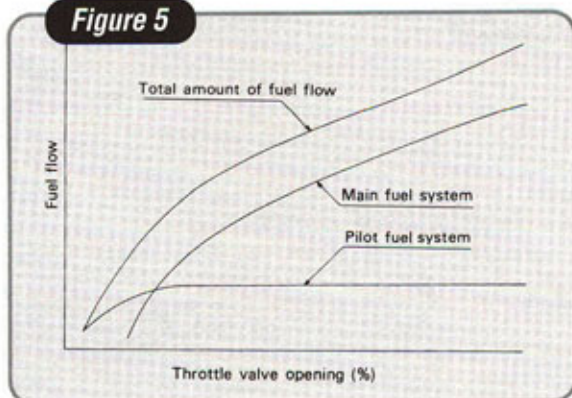

## Primary Type (Fig.6)

When the throttle valve is opened about 1/4 or more, the velocity of air flowing through the needle jet (10) increases and also the vacuum increases to the point where fuel can be sucked in. When the opening of throttle valve (1) is between a quarter and three quarters, fuel passes through the main jet (9) and, after being metered in the clearance between the needle jet (10) and the needle (11), it is mixed with air that is metered by the air jet (12) and atomization of the fuel is accelerated.

Figure 6

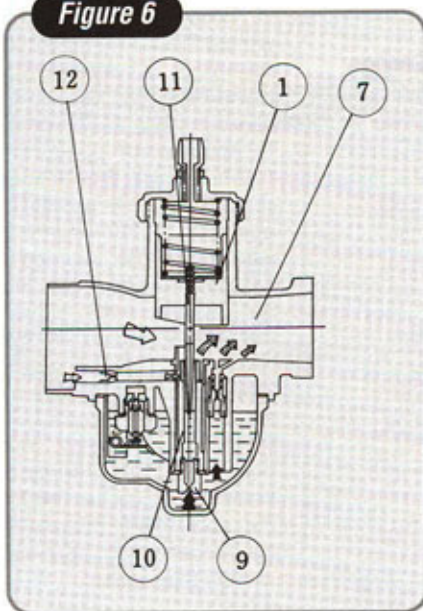

The mixture is then injected, after mixing with air flowing through the main bore (7), to the engine in the optimum air-fuel ratio. During this process of operation, the cutaway of the throttle valve serves to control the vacuum on the needle jet, thereby regulating the amount of fuel that is injected to the engine. When the throttle valve is opened more than three quarters high speed operation, fuel is metered chiefly by the main jet (9).

## Bleed Type (Fig.7)

The construction of the bleed-type (10) main fuel system is the same as that of the primary type, except for the bleed holes that are provided in the needle jets.

In the case of the primary type, air which comes from the main air jet is mixed with the raw fuel after it has been metered by needle jet and needle. This atomization takes place behind the nozzle screen or shroud above the needle jet outlet. The bleed type on the other hand is designed to bleed the air coming from the main air jet into the body section of the needle jet where it is emulsified with the fuel coming up from the bottom.

The needle jet and needle then meter a blend of air/fuel, resulting in a finer atomization and generally leaner mixture than the same size primary type needle jet.

Figure 7

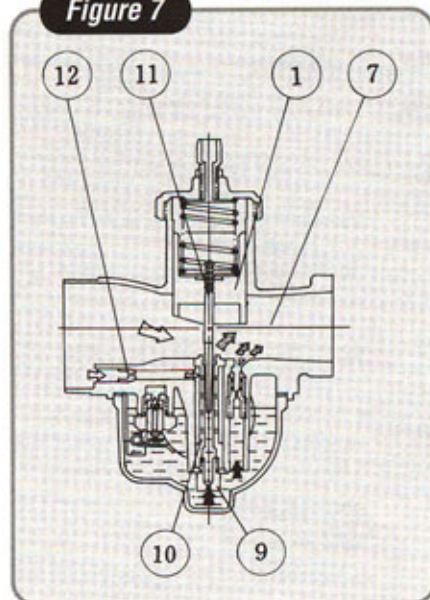

## C. - Float System (Fig.8)

The float system serves to maintain a constant level of fuel in the bowl. Fuel flows through the needle valve (14) and enters the float chamber (15). As the fuel enters the float chamber, the float (16) moves upward to its pre-determined level because of buoyancy. When the fuel reaches the pre-determined level, the needle valve begins to close due to the lever action of the float arm rising as the float attains buoyancy, thus shutting off the supply of fuel.

The fuel level in the bowl controls the amount of fuel which is metered to make the optimum fuel mixture. For example, too high a level allows more fuel than necessary to leave the needle jet, enriching the mixture. Too low a level results in a leaner mixture, as not enough fuel leaves the needle jet. Therefore, the pre-determined fuel level should not be changed arbitrarily.

Figure 8

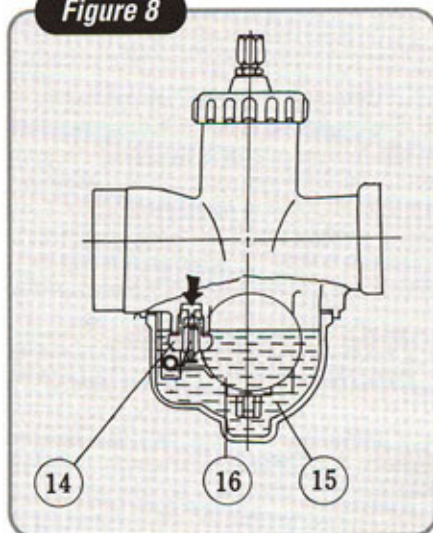

### D. - Starter System (Fig.9)

Rather than a choke, the enricher type starter system is employed for Mikuni carburetors. The enricher starter type, fuel and air, for starting the engine are metered by entirely independent jets. The fuel metered by the starter jet (17) is mixed with air and is broken into tiny particles in the emulsion tube (18). The mixture

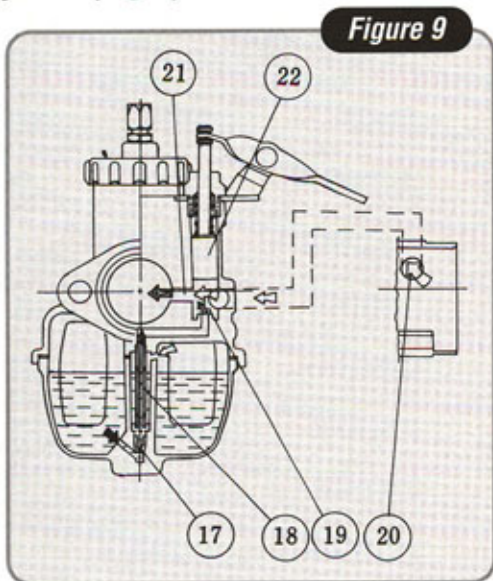

Figure 9

then flows into the plunger area (19), mixes again with air coming from the the air intake port for starting and is delivered to the engine in the optimum air-fuel ratio through the fuel discharge passage (21). The enricher is opened and closed by means of the starter plunger (22). Since the enricher is constructed so as to utilize the vacuum of the inlet passage (20), it is important that the throttle valve is closed when starting the engine.

## 4. TUNE UP & CARBURETOR SELECTION

Tuning up normally means a process of accurate and careful adjustment to obtain maximum engine performance. Although, it means in a broad sense, an economical improvement in fuel consumption. Improvement of power output of the engine depends on the amount of air drawn into the cylinder per unit time. A practice generally followed for engine tune-up includes:

- 1) To improve suction efficiency and exhaust efficiency by remodeling the intake and exhaust system
- 2) To improve combustion efficiency by raising the compression ratio
- 3) To increase the number of revolutions by adjusting the ignition timing

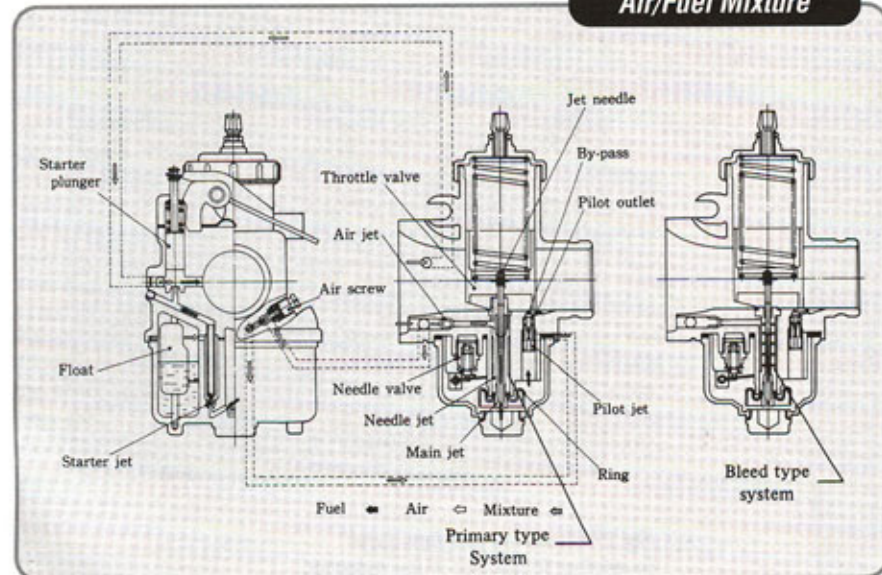
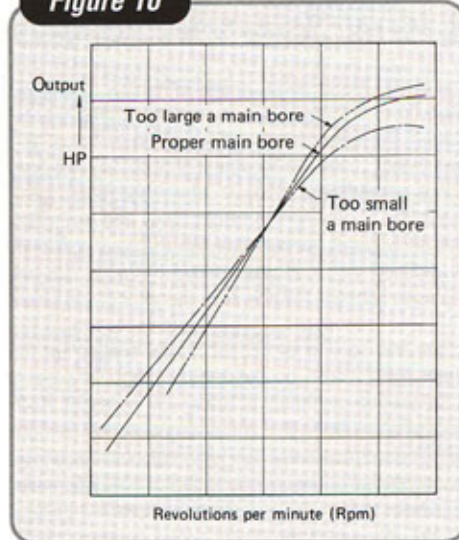

Figure 10



### A. - Carburetor Main Bore Size Selection

One of the prerequisites for improving the output is to use a carburetor with as large a main bore as possible. However, a large main bore alone does not necessarily improve the output. As shown in Fig.10, it is true that a large main bore improves the power output in the high speed range. However, in the slow speed range, the output may drop. The main bore size selection should be determined by various factors such as: (1) whether the vehicle is intended for racing, (2) the design of the engine, (3) riding technique of the rider, (4) the rider's preference, etc. In addition, the maximum output, the maximum torque, and the minimum number of revolutions for stable engine operation must also be taken into account. Fig.10 shows the values which we have obtained throughout experience over the years.

*Since the engine comes in a wide variety of types, the values given in Fig. 10 should be taken only as reference values.*

## 5. CARBURETOR SETTING

Once the main bore size of the carburetor is determined, a test (normally referred to as setting or matching) to select the proper jet or setting part should be made. The size of the jet is determined by measuring the output in a bench or in a chassis dyno test. For racing, it is best to determine the proper size of the jet on the racing course. The following points must be taken into account:

- 1) The altitude (atmospheric pressure), temperature and humidity of the racing course.
- 2) The operation of the engine based on the topography of the racing course.
- 3) Generally, carburetor tuning is done in four stages: idle, low speed, mid-range, and high speed in that order. With the Mikuni, each stage is controlled by a separate component simplifying the tuning process.

The engine cylinders need to take sufficient air and fuel mixed in proper amounts. The function of a carburetor is to prepare and supply a mixture of fuel vapor and air to the engine cylinders in the proper ratio for efficient combustion.

# General Mikuni Slide Carb Circuitry

## A. - Pilot Jet and the Low Speed Fuel System (Fig. 15 & 16) (Air Screw type carburetors only)

In the low speed fuel system of the carburetor, the pilot outlet and the bypass have holes whose size is in relation to the main bore of the carburetor. Hence, the adjustment and selection of the pilot jet and the air screw is important. Turn the throttle a little at no-load operation and see if the engine revolution increases smoothly. If the pilot jet is too small, increase in the engine speed will be slow and irregular. Too big a pilot jet, on the other hand, would give rise to heavy exhaust smoke as well as a dull exhaust noise. If you cannot maintain the speed in the range of 12-25 mph with the throttle held, the pilot is too small.

Selection and setting of the air screw should be made in the following manner. Engine warm up at idling will be about 10-20% higher than the number of revolutions you are aiming at. Then, turn the air screw left and right (between 1/4 and 1/2 turn) and select the position where the engine revolution reaches the maximum. Adjust the idle screw to bring down the engine revolution to your target speed for idling. After this adjustment of the idle screw is made, select once more the position where the engine revolution reaches the maximum, by turning the air screw left and right (between 1/4 and 1/2 alternately). At this point, attention should be paid to the following points.

- 1) If there is a certain range in the opening of the air screw where fast engine revolution can be obtained, (for instance, the number of revolutions does not change in the range of 1-1/2 to 2.0 turn), for better performance you should select approximately 1-1/2 turns.
- 2) To determine the "fully closed" position of the air screw, turn the air screw slightly. Excessive tightening of the air screw would damage the seat. The position where the air screw comes to a stop should be considered the "fully closed" position. The maximum number of turns in the opening of the air screw must be limited to 3.0. If the air screw is opened over 3.0 turns, the spring will not work and the air screw can come off during operation of the vehicle. Fig. 16 shows the fuel flow curve in relation to the opening of the air screw.

Figure 15

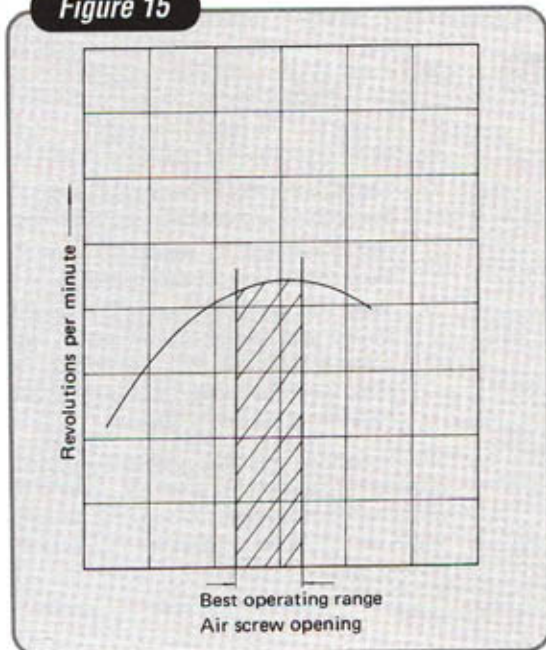
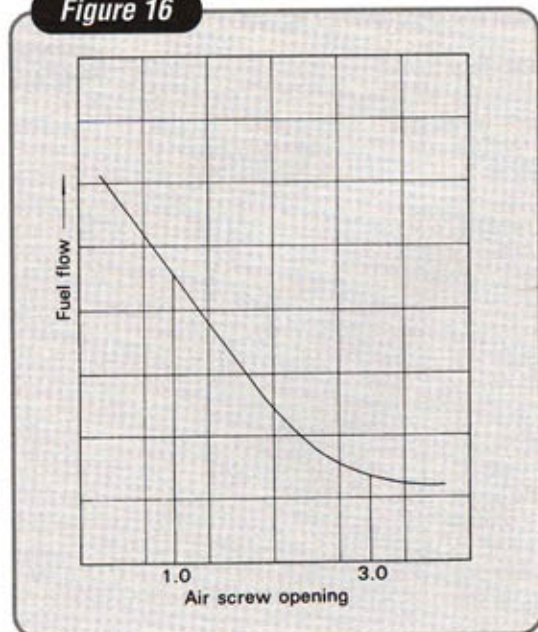

Figure 16



## B. - The Cutaway Size of the Throttle Valve (Fig. 17)

The size of the cutaway of the throttle valve affects the air-fuel mixture ratio when the degree of the throttle valve opening is between 1/8 and 1/2, especially in the range of 1/8 and 1/4 opening. As the cutaway gets larger in size, with the throttle valve opening kept unchanged, air inflow resistance is reduced and causes the amount of air to increase, resulting in a lean mixture. On the other hand, the smaller the size of the cutaway, the richer the air-fuel mixture will become. Interchange of the cutaway is made, when the low speed fuel system is out of balance with the main fuel system.

Figure 17

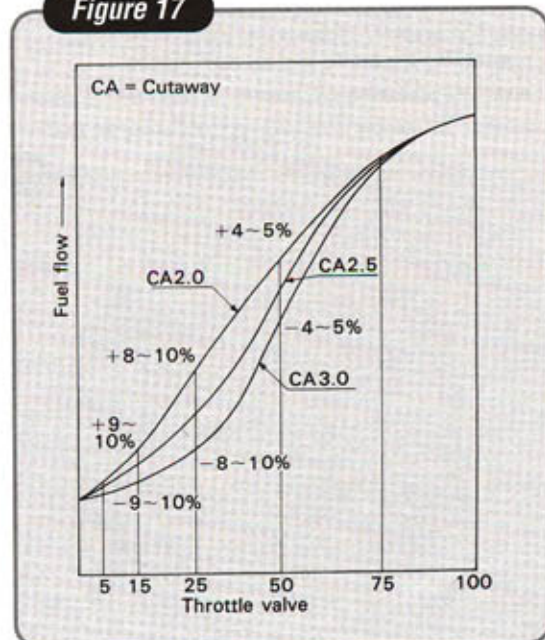
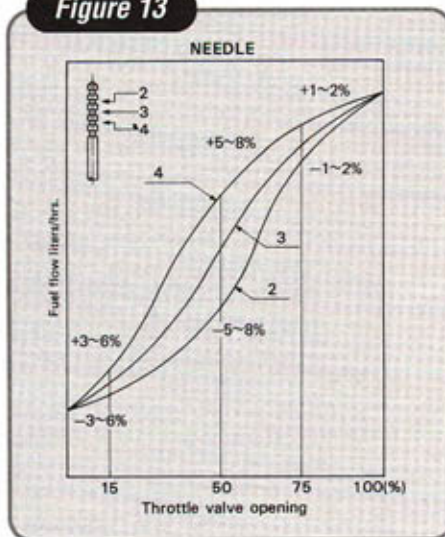

Fig. 17 shows the fuel flow curve in relation to the size of the cutaway.

### C. - Selection of NEEDLE JET and NEEDLE (Fig. 13 & 14)

A carburetor with a piston-type throttle valve is also called a variable venturi-type carburetor. In this type of carburetor, the needle jet and the needle serve to control a proper air-fuel mixture ratio during the so-called medium throttle valve opening (between 1/4 and 3/4 opening). The right combination of needle jet and needle will have a major bearing on the engine performance at partial load. The jet needle tapers off at one end and the clearance between the needle and the needle jet increases as the throttle valve opening gets wider. The air-fuel mixture is controlled by the height of the needle positioning clip that is inserted into one of the five slots provided in the head of the needle. The variation of fuel flow based on the height of the clip is shown in Fig. 13.

Figure 13



Generally, it is easier to evaluate and select a needle jet than it is to select a jet needle. The reason is that the needle jet sizes are arranged on a linear scale, with each size increasing in increments. (For a thorough explanation of needle jet sizes please refer to Chapter 5.) Jet needles are not cataloged according to a linear size pattern or a rich to lean scale. The most effective way to determine the needle jet / jet needle relationship is to visualize the jet needle as a tool for setting the fuel delivery curve, or the shape of the fuel delivery according to throttle opening. The needle jet controls the fuel delivery rate, either increasing or decreasing the fuel delivery according to the profile of the needle being used. Sudco suggests that initially, experiments should be limited to changes in needle jet size. Once a satisfactory size has been identified, experiment with needle clip position to obtain the best driveability and roll-on performance. If one is working with an O.E.M. Mikuni carburetor, it is safe to assume that the manufacturer has already selected the proper needle or "fuel curve" for that motorcycle and changing the needle profile will complicate the tuning process. Once the correct needle jet size has been identified and it becomes apparent that a change in needle profile is necessary, then refer to the needle dimension charts in Chapter 5.

Figure 14

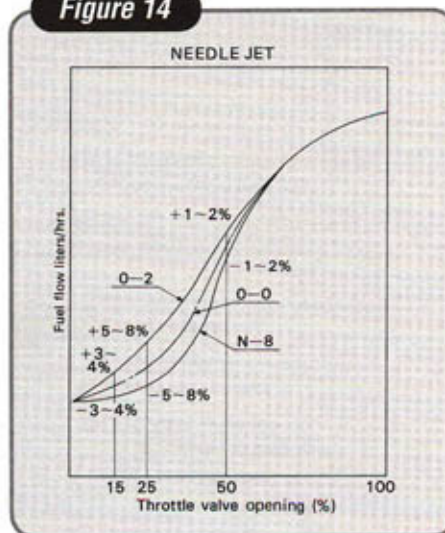

To evaluate the performance of the needle jet, run the motorcycle in third gear at 1/4 throttle, taking notes on how the engine accelerates from 1/4 to 1/2 throttle only. The engine should respond cleanly and crisply without sputtering or bogging. It may be useful to try experimenting with clip positions to decide if a problem is a rich or lean condition. If the engine response is better at a lean clip position, it may be necessary to change to a leaner needle jet. Sudco suggests that it is best to use as lean a needle jet as possible, as this component will have the greatest effect on fuel economy, emissions, and general driveability. If a leaner needle jet is installed and there is no negative impact on performance, and no positive effect, continue working in the direction of "lean" until there are negative results and go back up one size.

### D. - Selection of the Main Jet

First, do the following on a flat road.

- 1) Select the largest main jet (the limit of a rich mixture) which can give you the maximum revolutions per minute (the maximum speed). In this case, select the engine speed according to the dimensions of the test course.
- 2) Compare the gain in speed that you can obtain by quick acceleration from a constant speed of 25-30 MPH to maximum desired speed, by using different sizes of main jets.
- 3) Check the exhaust fumes and read the spark plug (selection of the spark plug should be made based on the thermal value that would best suit power output of the engine).

Next, compare on the racing course, the test results you obtained from above. The points to be checked, among others, are:

- 1) Smooth and steady operation of the engine at as high a speed as possible under varying operating conditions such as shifting of the gears, changes in road conditions, ascending and descending slopes, etc.
- 2) Sustained operation at low speeds and at heavy engine load.
- 3) Sustained operation at high speeds (without knocking or seizure).

**CAUTION:** Selection of too lean a main jet may cause severe engine overheating, and subsequent piston seizure. Fig. 12 shows comparison of fuel flow curves. The straight line is for Model C main jet and the dotted line for Model A and B main jets. In each model of main jet, different sizes within the range of +10% were tried.

Figure 12

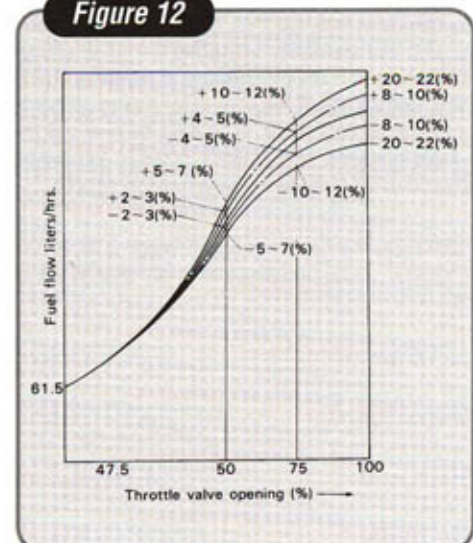

# General Mikuni Slide Carb Circuitry (Cont.)

## 6. MAINTENANCE

A carburetor consists of various precision-machined parts such as jets, needles, valves, etc. Therefore, care should be exercised, when removing jets or disassembling the carburetor for cleaning.

- 1) **Proper tools should be used for disassembling and reassembling of jets. Handle each part carefully to avoid scratches, bending, etc.**
- 2) **Wash the jets and the carburetor properly in solvent and blow them out with compressed air.**
- 3) **For carburetors whose main jet can be replaced from the outside, an "O" ring is used to prevent leakage of fuel. When you fit the "O" ring, apply a little lubricant or fuel.**
- 4) **It is important to maintain the fuel level in the carburetor. Do not touch the float arm, when disassembling the carburetor. If the float arm is bent accidentally, adjust the height of rib to the specific measurement (refer to Fig. 18).**

**Figure 18**

Model	VM26 -74	VM28 -49	VM30 -44	VM32 -33	VM34 -20	VM36 -4	VM38 -3	VM40 -1	VM44 -1
H (Inch) (mm)	.59~.66 15~17	.59~.66 15~17	.86~.94 22~24	.86~.94 22~24	.86~.94 22~24	.66~.74 17~19	.66~.74 17~19	.66~.74 17~19	.66~.74 17~19

**Float Height information for other carburetor designs is listed within the section pertaining to that carburetor.**

## 7. TUNING THE CARBURETOR FOR RACING

The maximum output of the engine depends on:

- 1) **The amount of air drawn into the cylinders**
- 2) **Whether an air-fuel mixture is delivered to the cylinders in a proper ratio**

Since the amount of air that is drawn into the the carburetor varies with the temperature, the atmospheric pressure, humidity, etc., the mixture ratio is also changed. It is important, therefore, that the fuel flow be adjusted in accordance with the altitude of the racing course and meteorological conditions prevailing.

### A. - Incoming Air in Relation to Meteorological Conditions

The amount of air drawn into the cylinders is influenced by such factors as the altitude, the temperature, the humidity, etc. Suppose that the amount of air sucked into the cylinders at an elevation of zero is taken as 100 (the temperature and humidity in this case are considered constant). The amount of air in question decreases in proportion to a rise in elevation as shown in Fig.19. Reduction in the amount of air drawn into the cylinders changes the air-fuel mixture ratio, with the result that the power output drops markedly. Fig.20 shows the relation between a rise in temperature and the amount of air drawn into the cylinders (in this case, the atmospheric pressure (elevation) and the humidity are considered unchanged and the amount of air going into the cylinders at 32 degrees F (0 degrees C) is taken as 100). In the case of the engine for racing where the maximum output is constantly called for, it is best to tune up the engine by making a matching test of the carburetor in accordance with the temperature and other conditions on the racing course.

**Figure 19**

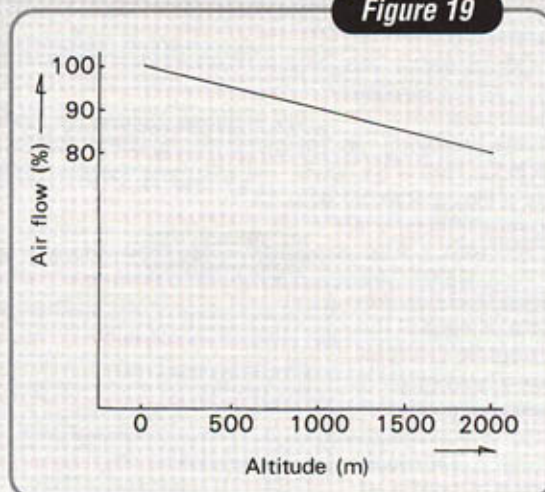

**Figure 20**

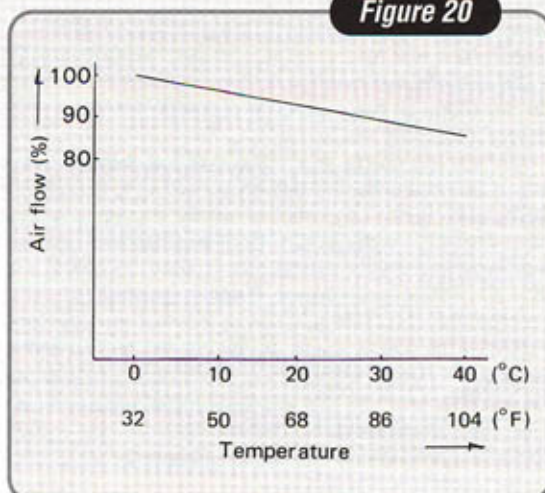



# Troubleshooting & General Procedures

When tuning motorcycle carburetors, there are several procedures and preliminary checks that will make the tuning and troubleshooting process go smoothly and quickly.

1. In order for carburetors to work properly, the engine must be in good mechanical condition. All of the following parameters should be checked in order to proceed with the carburetor tuning.

- A. **Compression** - all cylinders should be within 10% of each other according to cranking compression.
- B. **Valve Adjustment / Cam Timing** - check valve clearance according to the factory service manual, consult a qualified technician if there is any question about the cam timing.
- C. **Ignition Quality** - adjust point gap and ignition timing according to the factory service manual. Double check the gap and install new spark plug prior to any carburetor tuning.
- D. **Air Filter Quality** - Check to see that the air filter is clean and that all baffles and snorkels are in place, or have been removed as necessary for increased airflow. In any case, the air box / air filter dimensions should be finalized.
- E. **Exhaust System** - Install all mufflers and baffles. Double check all silencer packing and baffle installations. Finalize all exhaust system specifications before moving on to the carburetors. Jetting can vary dramatically according to muffler / baffle selection.

2. All fuel delivery circuits operate according to throttle position. In order to determine which circuit to tune, one must know the throttle opening at which there is a problem. Do not use R.P.M. to determine which circuit to tune. Sudco suggests the use of a throttle index on the twist grip to track the exact throttle opening of the carburetor.

## Throttle Index

- A. Place a piece of masking tape across the throttle housing adjacent to the twist grip so that it is visible from the riding position.
- B. Install a colored push pin or sewing pin into the throttle grip flange adjacent to the masking tape. Adjust the throttle cable free play to near zero.
- C. With the throttle closed, make a "0" mark on the masking tape adjacent to the pin head on the throttle flange.
- D. Open the throttle all the way and make a "W.O.T." mark on the masking tape adjacent to the pin head.
- E. Using a tape measure, divide the distance between the two marks on the tape into quarters and make marks for each throttle opening on the tape. (0, 1/4, 1/2, 3/4, W.O.T.)
- F. Ride the motorcycle and make mental notes regarding the carburetion according to the throttle index. If a problem is truly carburetor related, the symptoms will come and go according to the throttle position.

3. Work in progression from 0 throttle through full throttle. Motorcycle carburetor fuel circuits are additive. This means the main circuit delivery is an addition to the pilot circuit delivery. The pilot system delivers fuel at all throttle settings, therefore, the tuning of the pilot circuit will have some influence on the decisions to be made regarding the main circuit. If there is any question about the jetting of the pilot circuit it should be addressed first. After the pilot circuit has been optimized it is then possible to accurately evaluate the main circuit and it's related components.

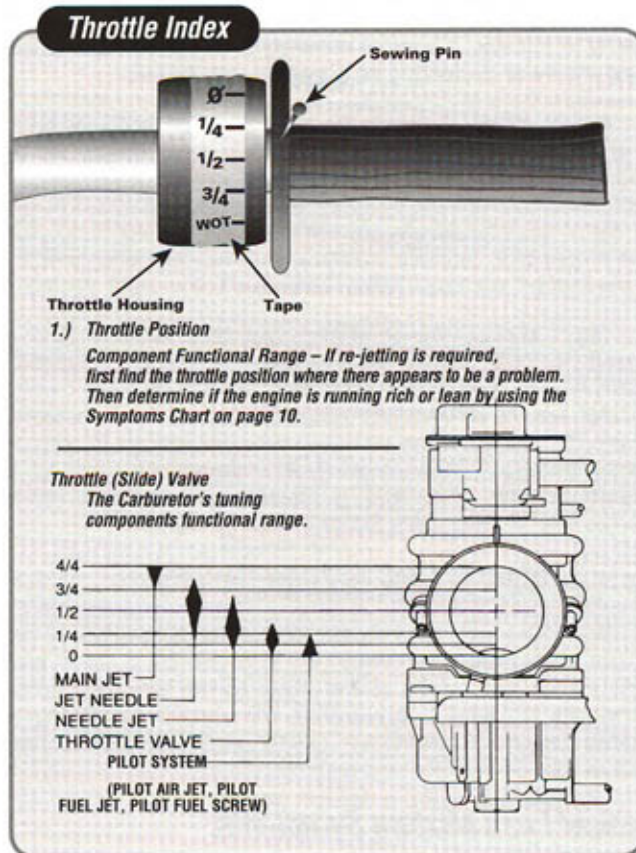

## 4. Altitude and Temperature

The purpose of the carburetor is to mix air and fuel in a specific ratio, by mass, in order to present a combustible mixture to the engine. Carburetors are generally flexible instruments when used to mix air and fuel in the proper ratio and will compensate for small changes in air density. It is when the altitude or temperature becomes extreme that it will be necessary to re-jet according to atmospheric conditions.

Altitude and temperature are important factors to consider when tuning carburetors for peak performance, as they directly affect air density. Notes should be taken regarding altitude and temperature changes as they occur in order to determine which way to go with carburetor adjustments.

Because air is a gas, its density is directly affected by altitude, barometric pressure, temperature and humidity. These factors will increase or decrease air density depending upon where you travel or how weather patterns develop in your riding area.

Gasoline is a liquid and cannot be compressed. Therefore, its density is not affected by altitude, temperature, or humidity.

# Troubleshooting & General Procedures

Because air density changes according to atmospheric conditions and fuel density does not, it becomes necessary to re-jet the carburetor according to changing altitude and weather conditions. As the density or mass of air changes, it becomes necessary to change the mass of fuel mixed with the air by changing the jets which meter the fuel.

Altitude affects air density the most. All other conditions being equal, as the elevation nears zero (sea-level), the air density will be greatest and the engine will require the richest carburetor settings that it will ever use. As elevation increases, the air density becomes less and the engine will require leaner carburetor settings in order to maintain peak performance. Generally, an engine which has been tuned correctly for sea-level will not require jetting changes until about 2500' elevation.

Temperature also has an affect on air density. As air temperature nears freezing (32 degrees F), the density of air will become greater. Conversely, as temperature rises toward 100 degrees F, air density becomes less. As air temperature decreases and air density becomes greater, the engine will require richer carburetor settings in order to maintain peak performance. Generally, an engine which has been tuned correctly for room temperature (72 degrees F) will not require jetting changes until the temperature change is about 20 degrees F.

## How To Identify Rich or Lean Conditions

Lean Condition - A lean condition is an out of balance air / fuel mixture where there is not enough fuel in the mixture to deliver peak performance. The results of lean mixtures can vary from minor driveability problems to overheating and possible severe engine damage. Care should be taken to identify lean mixtures and correct them as soon as possible.

### Typical Lean Mixture Symptoms:

1. *Engine acceleration is flat or slow to pick up.*
2. *It becomes difficult to apply the throttle quickly or the engine picks up speed when the throttle is rolled off.*
3. *The engine knocks, pings, or overheats.*
4. *The engine surges or hunts for a stable R.P.M. while cruising at part throttle.*
5. *When the pilot circuit is too lean there will be popping or spitting in the carburetors as the throttle is opened. Sometimes there will be popping or backfires in the exhaust system on engine deceleration after the throttle has been closed.*
6. *Engine performance improves in warmer weather conditions, or engine runs poorly in cold weather.*
7. *Engine performance worsens when the air filter is removed.*

Rich Condition - A rich condition is an out of balance air / fuel mixture where there is too much fuel in the mixture to deliver peak performance. A rich condition will result in excess carbon deposits within the combustion chamber and exhaust system, decreasing the life of the engine and related components. In addition to poor fuel economy, a rich running motorcycle will pollute excessively and contribute to environmental problems.

### Typical Rich Mixture Symptoms:

1. *Engine acceleration is flat, uneven, not crisp.*
2. *Two stroke engines will sputter or "4 stroke" and skip combustion cycles.*
3. *The throttle needs to be opened continuously to maintain consistent acceleration.*
4. *The engine performs poorly when the weather conditions get warmer, or the engine works better in cold conditions.*
5. *Excessive smoke from the tail pipe, black smoke from the tail pipe of four strokes.*
6. *Poor fuel economy.*
7. *Engine performance improves when air cleaner is removed.*
8. *When the pilot circuit is rich, the engine will idle roughly or not return to idle without blipping the throttle. The exhaust will smell of excessive fuel and burn the eyes.*
9. *Black, sooty or fouled spark plugs. Black and sooty exhaust tail pipes on four-strokes. Greasy and drippy tail pipes on two-strokes.*

# Carburetor Troubleshooting Guide

<b>PROBLEM</b>	<b>Possible Causes</b>	<b>CORRECTION</b>
<b>HARD STARTING.</b>	<i>Incorrect use of choke.</i>	<i>Correct use of choke.</i>
	<i>Incorrect air-fuel mixture adjustment.</i>	<i>Set mixture adjustment screw in accordance with owner's manual or shop manual instructions.</i>
	<i>Clogged fuel filter.</i>	<i>Clean filter.</i>
	<i>Clogged low speed fuel jets.</i>	<i>Disassemble carburetor and chemically clean.</i>
	<i>Clogged vent in fuel tank cap.</i>	<i>Unclog vent or replace cap.</i>
	<i>Float stuck.</i>	<i>Remove float bowl, check float operation, and correct or replace.</i>
	<i>Float damaged or leaking.</i>	<i>Replace float.</i>
	<i>Incorrect float level.</i>	<i>Set float height in accordance with shop manual specifications.</i>
	<i>Intake air leak.</i>	<i>Check carburetor mounting flanges for air leaks.</i>
	<i>Ignition problem.</i>	<i>Repair, replace, or adjust as necessary.</i>
	<i>Low cylinder compression.</i>	<i>Repair, replace, or adjust as necessary.</i>
<b>POOR IDLE OR STALLING.</b>	<i>Idle speed adjustment(s) set too low.</i>	<i>Adjust idle RPM in accordance with specifications in owner's manual or shop manual.</i>
	<i>Idle speed adjustments are unequal (twin and multi-carburetor models using individual throttle stop adjustments.)</i>	<i>Equalize throttle stop settings.</i>
	<i>Clogged idle &amp; low speed air bleed.</i>	<i>Disassemble carburetor and chemically clean.</i>
	<i>All causes listed under "HARD STARTING."</i>	
<b>IDLE MIXTURE ADJUSTMENT IS INEFFECTIVE. CARBURETOR DOES NOT RESPOND TO MOVEMENT OF THE IDLE MIXTURE SCREW.</b>	<i>Idle speed set too high.</i>	<i>Adjust idle speed in accordance with specifications in owner's manual or shop manual.</i>
	<i>Clogged low speed air-bleeds.</i>	<i>Disassemble carburetor and chemically clean.</i>
	<i>Damaged mixture adjustment needle.</i>	<i>Replace mixture adjustment needle.</i>
	<i>Mixture adjustment needle "O" ring is not sealing (models using "O" ring).</i>	<i>Replace "O" ring.</i>
	<i>Damaged mixture adjustment needle seat.</i>	<i>Replace carburetor.</i>
	<i>All carburetor problems listed under "HARD STARTING."</i>	

# Carburetor Troubleshooting Guide

PROBLEM	POSSIBLE CAUSE	CORRECTION
<b>SLOW RETURN TO IDLE.</b>	<i>Idle speed set too high.</i>	<i>Adjust idle speed in accordance with specifications in owner's manual or shop manual.</i>
	<i>Idle speed adjustments are unequal (twin and multi-carburetor models using individual throttle stop adjustments).</i>	<i>Equalize throttle stop settings.</i>
	<i>Throttle valve sticking.</i>	<i>Clean and inspect throttle valve and return spring. Replace as necessary.</i>
	<i>Throttle linkage sticking</i>	<i>Clean and inspect throttle linkage and return spring. Lubricate, repair, or replace as necessary.</i>
	<i>Throttle cable binding.</i>	<i>Correct routing or replace cable as necessary.</i>
<b>ENGINE SURGES WHEN AT A CONSTANT SPEED.</b>	<i>Incorrect air-fuel mixture adjustment.</i>	<i>Low speed - Low speed jet size change. Intermediate-Jet needle height adjustment.</i>
	<i>Vacuum piston sticking.</i>	<i>Clean and inspect vacuum piston and return spring. Replace if necessary.</i>
<b>ENGINE DOES NOT DEVELOP FULL POWER, OR MISSES ON ACCELERATION.</b>	<i>Incorrect use of choke.</i>	<i>Correct use of choke.</i>
	<i>Clogged air cleaner.</i>	<i>Clean or replace.</i>
	<i>Incorrect air-fuel mixture adjustment.</i>	<i>Low speed - Low speed jet size change. Intermediate - Jet needle height adj. High Speed - Main jet size change.</i>
	<i>Throttle valves not synchronized (models with two or more carburetors)</i>	<i>Adjust throttle valve synchronization.</i>
	<i>Clogged fuel filter.</i>	<i>Clean filter.</i>
	<i>Clogged fuel jets.</i>	<i>Disassemble carburetor and chemically clean.</i>
	<i>Clogged air bleeds.</i>	<i>Disassemble carburetor and chemically clean.</i>
	<i>Fuel jets loose.</i>	<i>Tighten fuel jets.</i>
	<i>Fuel jet "O" rings leaking (models using "O" rings).</i>	<i>Replace "O" rings.</i>
	<i>Float stuck</i>	<i>Remove float bowl, check float operation, and correct or replace.</i>
	<i>Float damaged or leaking.</i>	<i>Replace float.</i>
	<i>Incorrect float level.</i>	<i>Set float height in accordance with shop manual specifications.</i>
	<i>Vacuum piston sticking.</i>	<i>Clean and inspect vacuum piston and return spring. Replace if necessary.</i>
	<i>Vacuum piston diaphragm ruptured.</i>	<i>Replace vacuum piston assembly.</i>
	<i>Ignition problem.</i>	<i>Repair, replace, or adjust as necessary.</i>
<i>Low cylinder compression.</i>	<i>Repair, replace, or adjust as necessary.</i>	

# Carburetor Synchronization

Motorcycle carburetor synchronization is best described as a process where it becomes necessary to keep two, three, or four engines running at exactly the same speed, where each cylinder on the motorcycle is a separate engine. In order to match the speed of each cylinder to the next, the slide lift must be exactly the same on each carburetor. Given an engine with perfect cylinder compression, ignition timing, and mixture quality, all cylinders will run at exactly the same speed when the carbs are in exact mechanical synchronization.

## Synchronizing Mikuni VM, TM and TMX Single Carbs

There are two synch procedures to execute when setting up single type carbs on multis. The first is idle synch and the second is cable synch, to be done in that order.

The easiest way to start the idle synch process is to choose an arbitrary slide lift setting. Set each one at exactly the same lift with the throttle stop screw (idle speed screw). Generally a 1mm (.040") lift will be sufficient to start with. Use round wire as a feeler gauge under each slide to match the slide lifts at idle. Check the air screw/fuel screw settings and match as necessary at this time.

Mount the carburetors and attach the throttle cables. Start the engine and adjust the idle speed screws in or out, counting each 1/2 turn and setting each carburetor the same amount, bearing in mind that each slide needs to be kept at equal lift. The engine will idle smoothly when all the slides are adjusted properly. Turn the engine off.

Now that the idle synch has been established, it is possible to synch the cables that lift each slide. Using the cable adjuster mounted on each carburetor top, take out all the cable free play until the slide starts to lift off idle. Back this adjustment off until the slide just returns to idle. Do this for each carburetor. The cables are now roughly synchronized. Put a finger on the slide of the #1 carburetor and watch the slide on the #2 carburetor. Slowly twist the throttle to lift the slides, both slides should lift off idle at the same instant. If the slides are out of synch, adjust the retarded carburetor with the cable adjuster on the carb top to match the other carb. Repeat this process, matching the #3 carburetor to the #2 carburetor and so on for all of the cylinders. Check the cable free play at the twist throttle, there should be about 1mm throttle free play. Double check and tighten all lock nuts and screws as necessary.

## Synchronizing Mikuni Smoothbore Carburetors

Sudco recommends that all smoothbore type carburetors be synchronized mechanically rather than with vacuum gauges or mercury manometer ("carb stick"). There are several reasons that vacuum synchronization is not recommended.

1. The synch adjustments on smoothbore carburetors are underneath the top cover of the carburetor, which when removed exposes a large vacuum leak to the cylinder being adjusted, resulting in inconsistent vacuum levels from one carb to the next.

2. The vacuum shown on a gauge is a result of several engine conditions: cylinder compression, spark quality and timing, mixture quality, and carburetor slide lift. If any one of these parameters is not perfect it will become increasingly difficult to get a consistent vacuum level, regardless of slide lift.

3. Carburetor circuitry is throttle position sensitive. If the slides are not in exact mechanical synch, then one carburetor may be operating on a different circuit than the others.

## Mechanically Synchronizing Smoothbore Carburetors

1. Remove the carburetors from the engine and drain float bowls.

2. Remove the top cover from each carburetor and note which carburetor does not have a synch adjuster. Some designs will have adjusters on all the carbs, some will have a fixed or non-adjustable carb. Usually, #2 or the one closest to the throttle wheel.

3. With the carburetors on the work bench and the spigot or engine side of the carbs facing you, adjust the idle speed screw so that the slides are nearly closed.

4. Place a piece of fine wire or rod about .020" (.5mm) thick underneath the fixed adjustment carburetor slide. Use the idle speed screw to adjust the tension on the wire gauge, which should slip between the slide and carburetor bore with some slight drag. If your particular carburetor design does not have a fixed adjuster, then use the carburetor closest to the throttle cable wheel and set the idle adjuster as described above. This is now the baseline carburetor.

5. Using the same piece of wire or exact duplicates, check the slide lift of all the other carburetors against the wire gauge. If the drag on the wire gauge is not the same as the baseline carburetor, adjust the slide lift of each carburetor with the synch adjuster located at the throttle shaft/lift arm joint, so that the drag on the wire is the same as the baseline carburetor.

Sometimes, the synch adjusters are adjust nuts and lock screws, where the slide lift adjustment is made by turning the nut and then is locked in place with the screw in the center. Double check the adjust method used on your particular carburetor and proceed carefully.

6. Once all the slides have been synchronized, open and close the throttles several times, checking for binding or sticking. Double check the synchronization at idle by sight. Turn the idle speed adjustment out and watch the clearance between the slides and their carb bores. As the clearance nears zero, any difference in slide lift will become apparent. Correct the differences as necessary.

7. Replace the carburetor tops, check the gaskets for leaks. Double check the fuel screw/air screw settings at this time, re-set to the standard specification. Install the carburetors and adjust the throttle cables for correct free play at the throttle .020" to .040" (0.5 to 1.0mm)

8. Now that the carburetors have been properly synchronized, it is possible to use a vacuum gauge or carb sticks to optimize the fuel screw/air screw settings. With the engine idling, experiment with the mixture screw while looking for an increase in manifold vacuum. The screw setting which produces the highest vacuum level is generally the correct position.

# Carburetor Synchronization (Continued)

## Synchronization of Smoothbore Carbs - As viewed from engine side of carbs.

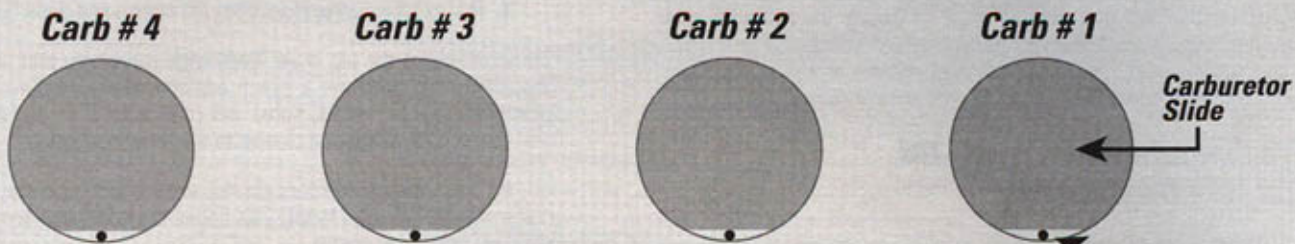

1. Synch the carbs from the engine side.
2. Use round wire as a feeler gauge.
3. #2 or #3 is the "fixed" or baseline carb. Use idle speed adjuster to set the height against the gauge.
4. Use synch adjusters inside carb top to adjust the other carbs.
5. Carbs are in synch when all slide lifts are equal.

## Single Carb Synchronization

1. Synch the carbs initially with the idle speed adjusters.
2. Adjust the engine speed for correct idle with the idle speed adjusters (keep them matched, use a vacuum gauge as necessary.)
3. Adjust cable synch with the cable adjusters, so that all slides lift off idle at exactly the same moment. Use a finger on one slide and watch the other.
4. Adjust the air screws for proper idle mixture quality. Use a vacuum gauge if necessary. Mixture is correct when vacuum is at the highest level.

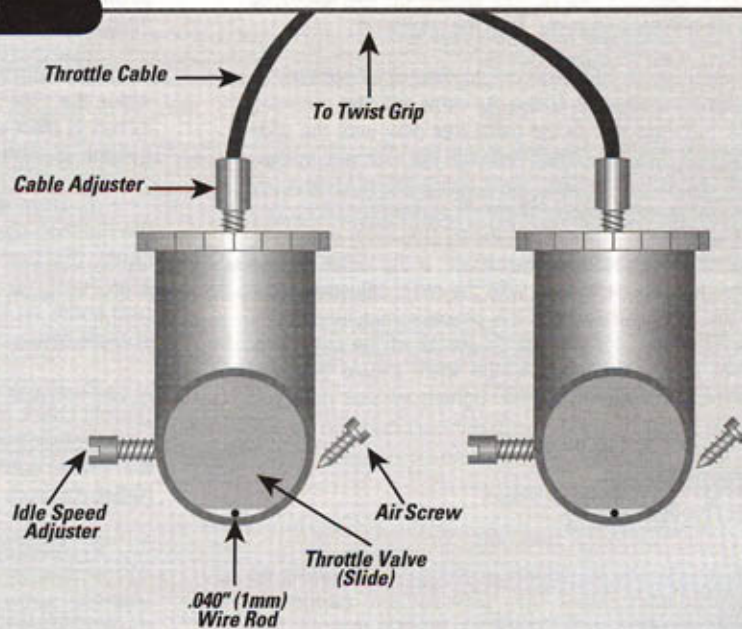

# Reading Spark Plugs to evaluate carburetor performance

The facing page shows spark plugs which have been carefully cut away to reveal the finer points of spark plug analysis. While this cutaway method is not practical for general plug reading, you now have some easy to see samples for comparison purposes.

Please study the photos carefully and compare them to the spark plugs removed from your engine, you will find this to be the best way to make the final detailed analysis of your carburetor performance.

## Procedures for reading spark plugs:

1. Have most of the carburetor settings finalized before reading the plugs, it is generally only possible to evaluate the main jet when reading plugs, so have all the low speed low throttle adjustments worked out first.
2. Finalize all the other tuning variables, ignition timing, fuel quality, muffler specification, etc.
3. Warm up the engine to operating temperature, ride it for 5-10 minutes and remove the old spark plugs. Install new properly gapped spark plugs of the correct heat range for your engine.
4. Ride the motorcycle aggressively for about 4-5 miles, don't cruise, use the whole power/rev range. This will put some deposit on the plug without contaminating it for the main jet run.
5. **Main Jet Run and Plug Chop**  
While riding up a slight hill, hold the throttle wide open in an upper gear. When engine r.p.m. reaches red line:
  - 1) Hit the kill switch
  - 2) Pull in the clutch
  - 3) Close the throttle
  - 4) Coast to a stop with the clutch pulled in.This will "photograph" the main jet mixture strength on the porcelain insulator, positive electrode and ground electrode of the spark plug.

6. **Remove and evaluate the plug deposit.**  
Use a magnifying glass and bright light to compare the fuel deposit pattern on the porcelain insulator to a brand new plug. The insulator should be generally clean and white from the center electrode down the body of the insulator with the fuel deposit appearing toward the base of the insulator in the form of a gray/black smoke ring. The intensity and width of the smoke ring will vary according to the size of the main jet. There should be some slight deposit on the center electrode and some deposit on the ground electrode as well, some slight bluing of the ground electrode is acceptable.

Compare your sample to the chart on the right and make main jet changes according to the fuel deposit. The ideal carburetor settings are those which produce good driveability and performance, and leave a minimum of fuel deposit on the plugs. Work towards a narrow smoke ring deposit. If changes to the main jet size are necessary, it is best to install new spark plugs and repeat the plug coloring/plug chop process. Compare all plug readings to a new plug and track the intensity of the smoke ring/fuel deposits as performance improves.

# Reading Spark Plugs (Photos courtesy of Champion Spark Plugs)

A correctly tuned engine will show a light deposit (some coloration) on the center wire, core nose and ground wire.

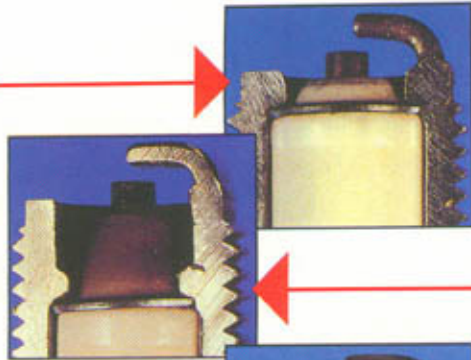

A plug fouled with carbon deposits was running too rich.

Specs on the core nose is a sign of detonation.

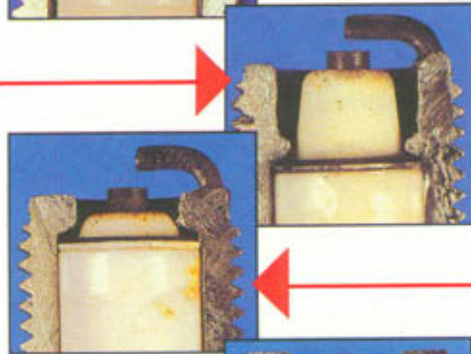

This is another example of detonation.

A build-up of residue on the center wire and darker coloration on the ceramic is a sign the plug is too rich.

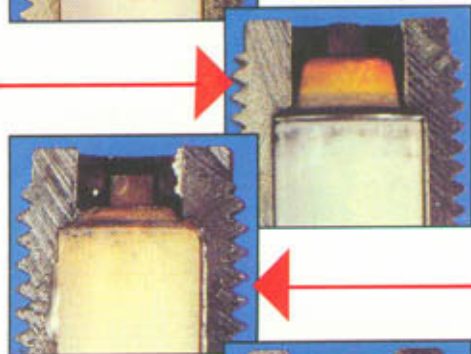

This plug is from an engine running on alcohol. Discoloration on the ceramic is a sign the plug is too rich.

When an alcohol plug is right on target you won't find any blistering, fusing build-up of debris or erosion of the center or ground wires.

